

100M~2.5Gb/s DWDM SFP Transceiver

2G-DSxx-EZX

■ Product Features

- ✓ Up to 2.5Gb/s data links
- ✓ Duplex LC connector
- ✓ Hot-pluggable SFP footprint
- ✓ Uncooled DFB laser transmitter
- ✓ RoHS compliant and Lead Free
- ✓ Up to 120Km on 9/125um SMF
- ✓ 100GHz channel spacing
- ✓ Metal enclosure for lower EMI
- ✓ Single +3.3V power supply
- ✓ Power dissipation <1.8W
- ✓ SFP MSA SFF-8074i Compliant

■ Applications

- ✓ Gigabit Ethernet
- ✓ 1x Fibre Channel

■ General

Fiberend's 2G-DSxx-EZX Small Form Factor Pluggable (SFP) transceivers are compatible with the Small Form Factor Pluggable Multi-Sourcing Agreement (MSA). It is designed for DWDM SONET/ SDH, Gigabit Ethernet and Fiber-Channel applications.

■ Product Channel Selection

Product Code	ITU channel	Frequency	Center Wavelength(nm)
2G-DS61-EZX	61	196.1	1528.77
2G-DS60-EZX	60	196.0	1529.55
2G-DS59-EZX	59	195.9	1530.33
2G-DS58-EZX	58	195.8	1531.12
2G-DS57-EZX	57	195.7	1531.90
2G-DS56-EZX	56	195.6	1532.68
2G-DS55-EZX	55	195.5	1533.47
2G-DS54-EZX	54	195.4	1534.25

2G-DS53-EZX	53	195.3	1535.04
2G-DS52-EZX	52	195.2	1535.82
2G-DS51-EZX	51	195.1	1536.61
2G-DS50-EZX	50	195.0	1537.40
2G-DS49-EZX	49	194.9	1538.19
2G-DS48-EZX	48	194.8	1538.98
2G-DS47-EZX	47	194.7	1539.77
2G-DS46-EZX	46	194.6	1540.56
2G-DS45-EZX	45	194.5	1541.35
2G-DS44-EZX	44	194.4	1542.14
2G-DS43-EZX	43	194.3	1542.94
2G-DS42-EZX	42	194.2	1543.73
2G-DS41-EZX	41	194.1	1544.53
2G-DS40-EZX	40	194.0	1545.32
2G-DS39-EZX	39	193.9	1546.12
2G-DS38-EZX	38	193.8	1546.92
2G-DS37-EZX	37	193.7	1547.72
2G-DS36-EZX	36	193.6	1548.51
2G-DS35-EZX	35	193.5	1549.32
2G-DS34-EZX	34	193.4	1550.12
2G-DS33-EZX	33	193.3	1550.92
2G-DS32-EZX	32	193.2	1551.72
2G-DS31-EZX	31	193.1	1552.52
2G-DS30-EZX	30	193.0	1553.33
2G-DS29-EZX	29	192.9	1554.13
2G-DS28-EZX	28	192.8	1554.94
2G-DS27-EZX	27	192.7	1555.75
2G-DS26-EZX	26	192.6	1556.55
2G-DS25-EZX	25	192.5	1557.36

2G-DS24-EZX	24	192.4	1558.17
2G-DS23-EZX	23	192.3	1558.98
2G-DS22-EZX	22	192.2	1559.79
2G-DS21-EZX	21	192.1	1560.61
2G-DS20-EZX	20	192.0	1561.42
2G-DS19-EZX	19	191.9	1562.23
2G-DS18-EZX	18	191.8	1563.05
2G-DS17-EZX	17	191.7	1563.86

■ Regulatory Compliance

- ESD to the Electrical PINs: compatible with MIL-STD-883 Method 3015
- ESD to the Duplex LC Receptacle: compatible with IEC 61000-4-2
- Immunity compatible with IEC 61000-4-3
- EMI compatible with FCC Part 15 Class B EN55022 Class B (CISPR 22B) VCCI Class B
- Laser Eye Safety compatible with FDA 21CFR 1040.10 and 1040.11 EN60950, EN (IEC) 60825-1,2
- RoHS compliant with RoHS 2 (2011/65/EU)

■ Pin Descriptions

Pin	Symbol	Name/Description	Ref.
1	VeeT	Transmitter Ground (Common with Receiver Ground)	1
2	TX Fault	Transmitter Fault.	
3	TX Disable	Transmitter Disable. Laser output disabled on high or open.	2
4	MOD_DEF(2)	Module Definition 2. Data line for Serial ID.	3
5	MOD_DEF(1)	Module Definition 1. Clock line for Serial ID.	3
6	MOD_DEF(0)	Module Definition 0. Grounded within the module.	3
7	Rate Select	No connection required	
8	LOS	Loss of Signal indication. Logic 0 indicates normal operation.	4
9	VeeR	Receiver Ground (Common with Transmitter Ground)	1
10	VeeR	Receiver Ground (Common with Transmitter Ground)	1
11	VeeR	Receiver Ground (Common with Transmitter Ground)	1

12	RD-	Receiver Inverted DATA out. AC Coupled	
13	RD+	Receiver Non-inverted DATA out. AC Coupled	
14	VeeR	Receiver Ground (Common with Transmitter Ground)	1
15	VccR	Receiver Power Supply	
16	VccT	Transmitter Power Supply	
17	VeeT	Transmitter Ground (Common with Receiver Ground)	1
18	TD+	Transmitter Non-Inverted DATA in. AC Coupled.	
19	TD-	Transmitter Inverted DATA in. AC Coupled.	
20	VeeT	Transmitter Ground (Common with Receiver Ground)	1

Notes:

1. Circuit ground is internally isolated from chassis ground.
2. Laser output disabled on TX Disable >2.0V or open, enabled on TX Disable <0.8V.
3. Should be pulled up with 4.7k - 10kohms on host board to a voltage between 2.0V and 3.6V.
MOD_DEF (0) pulls line low to indicate module is plugged in.
4. LOS is open collector output. Should be pulled up with 4.7k – 10kohms on host board to a voltage between 2.0V and 3.6V. Logic 0 indicates normal operation; logic 1 indicates loss of signal.

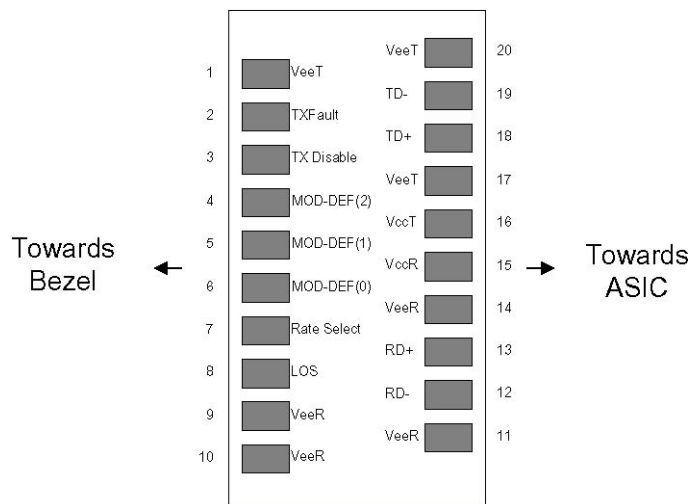

Pin-out of Connector Block on Host Board

■ **Recommend Circuit Schematic**

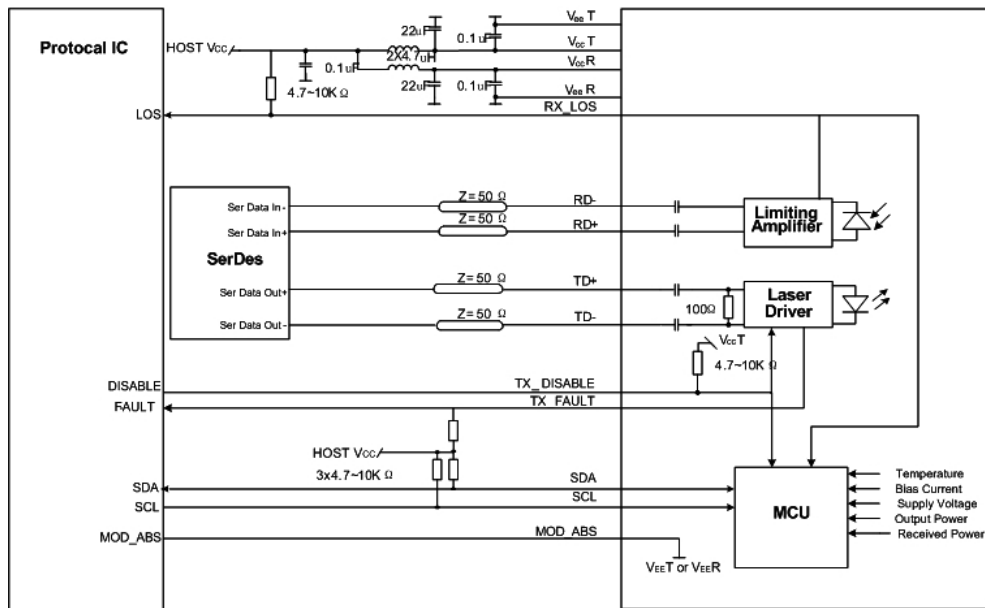

■ Absolute Maximum Ratings

Parameter	Symbol	Min	Typ	Max	Unit	Ref.
Maximum Supply Voltage	Vcc	-0.5		+4.0	V	
Storage Temperature	TS	-40		+85	°C	
Operating Humidity	RH	0		85	%	

■ Recommended Operating Conditions

Parameter	Symbol	Min	Typ	Max	Unit	Ref.
Power Supply Voltage	Vcc	3.13	3.30	3.47	V	
Power Supply Current	Icc			500	mA	
Case Operating Temperature	Tc	0		+70	°C	1
	Tl	-40		+85		2
Data Rate(Gigabit Ethernet)			1.25		Gbps	
Data Rate(Fibre Channel)			1.063		Gbps	
9/125um G.652 SMF	Lmax			120	km	

Notes:

1. For commercial class product.
2. For industrial class product.

■ Electrical Characteristics (TOP=25°C, Vcc=3.3Volts)

Parameter	Symbol	Min	Typ	Max	Unit	Ref.
Transmitter						
Input differential impedance	Rin		100		Ω	1
Single ended data input swing	Vin, pp	250		1200	mV	
TX Disable-High		Vcc – 1.3		Vcc	V	
TX Disable-Low		Vee		Vee+ 0.8	V	
TX Fault-High		Vcc-0.5		Vcc	V	
TX Fault-Low		Vee		Vee+0.5	V	
Receiver						
Single ended data output swing	Vout, pp	300	400	800	mV	2
Data output rise time	tr			175	ps	3
Data output fall time	tf			175	ps	3
LOS-High		Vcc – 0.5		Vcc	V	
LOS-Low		Vee		Vee+0.5	V	

Notes:

1. AC coupled.
2. Into 100 ohm differential termination.
3. 20 – 80 %

■ Optical Characteristics (TOP=25°C, Vcc=3.3 Volts)

Parameter	Symbol	Min	Typ	Max	Unit	Ref.
Transmitter						
Output Opt. Power	PO	0		+4	dBm	1
Optical Wavelength	λ	As per ITU-T 694.1			nm	
Spectral Width(-20dB)	Δ λ			1	nm	
Side Mode Suppression Ratio	SMSR	30			dB	
Total Jitter	TJ			0.35	UI	
Optical Extinction Ratio	ER	9			dB	
Center Wavelength	λc EOL	z-100	z	Z+100	pm	

Receiver						
RX Sensitivity @2.488Gb/s	SENS			-30	dBm	2,3
Receiver Overload		-9			dBm	
Optical Center Wavelength	λ C	1270		1600	nm	
LOS De-Assert	LOSD			-32	dBm	
LOS Assert	LOSA	-45			dBm	
LOS Hysteresis		0.5		5	dB	

Notes:

1. Class 1 Laser Safety.
2. Measured with conformance signals defined in FC-PI-2 Rev. 10.0 specifications.
3. Measured with PRBS 2⁷ -1 at 10⁻¹² BER.

Mechanical Specifications

Fiberend's Small Form Factor Pluggable (SFP) transceivers are compatible with the dimensions defined by the SFP Multi-Sourcing Agreement (MSA), dimensions are in mm.

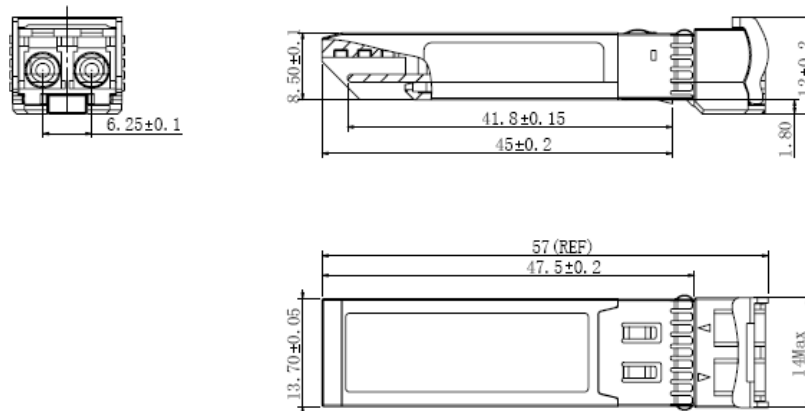

2G-DSxx-EZX

EEPROM Information

EEPROM memory map specific data field description is as below:

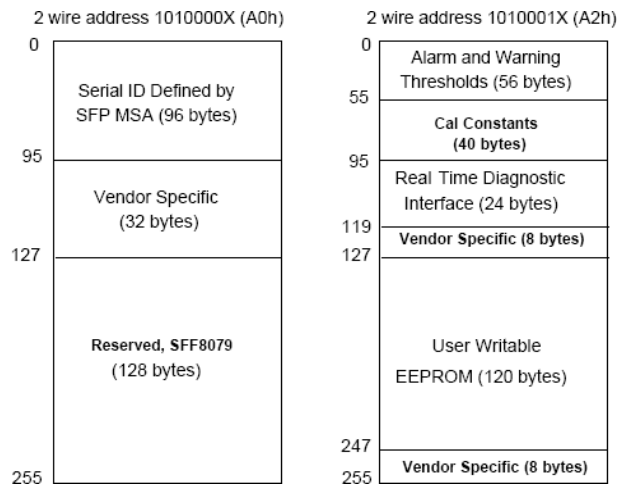

■ Digital Diagnostic Monitoring Interface

Five transceiver parameter values are monitored. The following table defines the monitored parameter's accuracy.

Parameter	Range	Accuracy	Calibration
Temperature	0 to +70°C (C)	±3°C	Internal
	-40 to +85°C (I)		
Voltage	2.97 to 3.63V	±3%	Internal
Bias Current	0 to 100mA	±10%	Internal
TX Power	0 to +4dBm	±3dB	Internal
RX Power	-30 to -9dBm	±3dB	Internal