

1.25 Gb/s SFP BIDI Transceiver

1G-BS4931-SX

■ Product Features

- ✓ Up to 1.25Gb/s data links
- ✓ Single LC connector
- ✓ Hot-pluggable SFP footprint
- ✓ 1490nm DFB laser transmitter
- ✓ RoHS compliant and Lead Free
- ✓ Up to 3Km on 9/125um SMF
- ✓ Metal enclosure for lower EMI
- ✓ Single +3.3V power supply
- ✓ Power dissipation <800mW (0~70°C), <1000mW (-40~85°C)
- ✓ Commercial and industrial operating temperature optional
- ✓ SFP MSA SFF-8074i Compliant



■ Applications

- ✓ Gigabit Ethernet

■ General

Fiberend's 1G-BS4931-SX Small Form Factor Pluggable (SFP) transceivers are compatible with the Small Form Factor Pluggable Multi-Sourcing Agreement (MSA). The SFP transceivers are high performance, cost effective modules supporting Gigabit Ethernet and 3km transmission distance with SMF. They are RoHS compliant and lead-free.

■ Product Selection

Part Number	Operating temperature	DDMI
1G-BS4931-SX	Commercial	Yes
1G-BS4931-SXI	Industrial	Yes

■ Regulatory Compliance

- ESD to the Electrical PINs: compatible with MIL-STD-883 Method 3015
- ESD to the Single LC Receptacle: compatible with IEC 61000-4-2
- Immunity compatible with IEC 61000-4-3
- EMI compatible with FCC Part 15 Class B EN55022 Class B (CISPR 22B) VCCI Class B
- Laser Eye Safety compatible with FDA 21CFR 1040.10 and 1040.11 EN60950, EN (IEC) 60825-1,2
- RoHS compliant with RoHS 2 (2011/65/EU)

■ Pin Descriptions

Pin	Symbol	Name/Description	Ref.
1	VeeT	Transmitter Ground (Common with Receiver Ground)	1
2	TX Fault	Transmitter Fault.	
3	TX Disable	Transmitter Disable. Laser output disabled on high or open.	2
4	MOD_DEF(2)	Module Definition 2. Data line for Serial ID.	3
5	MOD_DEF(1)	Module Definition 1. Clock line for Serial ID.	3
6	MOD_DEF(0)	Module Definition 0. Grounded within the module.	3
7	Rate Select	No connection required	
8	LOS	Loss of Signal indication. Logic 0 indicates normal operation.	4
9	VeeR	Receiver Ground (Common with Transmitter Ground)	1
10	VeeR	Receiver Ground (Common with Transmitter Ground)	1
11	VeeR	Receiver Ground (Common with Transmitter Ground)	1
12	RD-	Receiver Inverted DATA out. AC Coupled	
13	RD+	Receiver Non-inverted DATA out. AC Coupled	
14	VeeR	Receiver Ground (Common with Transmitter Ground)	1
15	VccR	Receiver Power Supply	
16	VccT	Transmitter Power Supply	
17	VeeT	Transmitter Ground (Common with Receiver Ground)	1
18	TD+	Transmitter Non-Inverted DATA in. AC Coupled.	
19	TD-	Transmitter Inverted DATA in. AC Coupled.	
20	VeeT	Transmitter Ground (Common with Receiver Ground)	1

Notes:

1. Circuit ground is internally isolated from chassis ground.
 2. Laser output disabled on TX Disable >2.0V or open, enabled on TX Disable <0.8V.
 3. Should be pulled up with 4.7k - 10kohms on host board to a voltage between 2.0V and 3.6V.
- MOD_DEF (0) pulls line low to indicate module is plugged in.
4. LOS is open collector output. Should be pulled up with 4.7k – 10kohms on host board to a voltage between 2.0V and 3.6V. Logic 0 indicates normal operation; logic 1 indicates loss of signal.

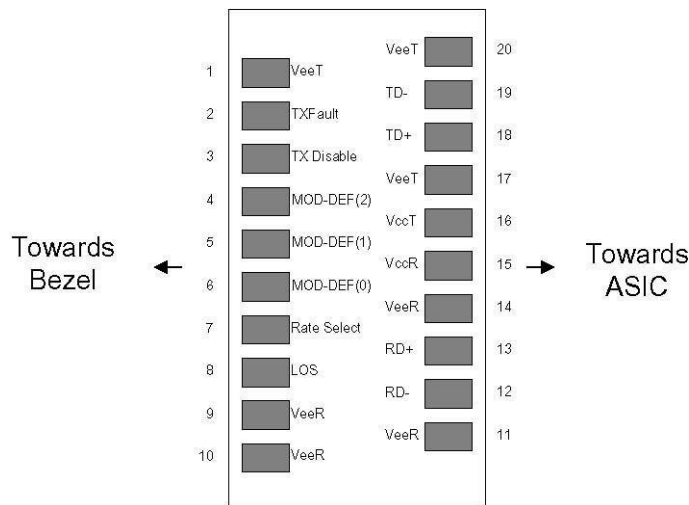

Pin-out of Connector Block on Host Board

■ Recommend Circuit Schematic

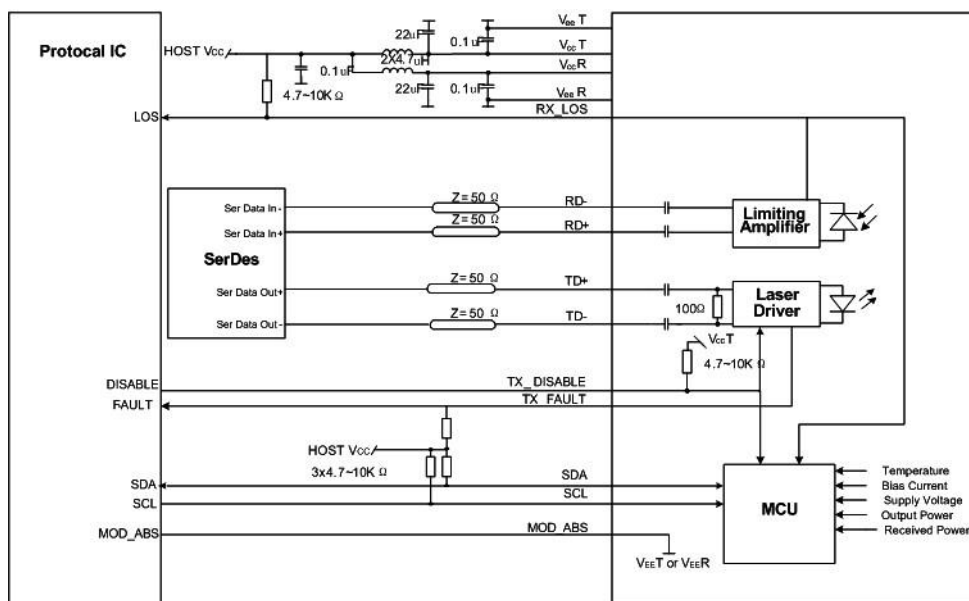

■ Absolute Maximum Ratings

Parameter	Symbol	Min	Typ	Max	Unit	Ref.
Maximum Supply Voltage	Vcc	-0.5		+4.0	V	
Storage Temperature	TS	-40		+85	°C	
Operating Humidity	RH	0		85	%	

■ Recommended Operating Conditions

Parameter	Symbol	Min	Typ	Max	Unit	Ref.
Power Supply Voltage	Vcc	3.13	3.30	3.47	V	
Power Supply Current	Icc			250	mA	Commercial
	Icc			300	mA	Industrial
Case Operating Temperature	Tc	0		+70	°C	1
	Tl	-40		+85		2
Data Rate(Gigabit Ethernet)			1.25		Gbps	
9/125um G.652 SMF	Lmax			3	km	

Notes:

1. For commercial class product.
2. For industrial class product.

■ Electrical Characteristics (TOP=25°C, Vcc=3.3Volts)

Parameter	Symbol	Min	Typ	Max	Unit	Ref.
Transmitter						
Input differential impedance	Rin	-	100	-	Ω	1
Single ended data input swing	Vin, pp	250	-	1200	mV	
TX Disable-High	-	Vcc – 1.3	-	Vcc	V	
TX Disable-Low	-	Vee	-	Vee+ 0.8	V	
TX Fault-High	-	Vcc-0.5	-	Vcc	V	
TX Fault-Low	-	Vee	-	Vee+0.5	V	
Receiver						

Single ended data output swing	Vout, pp	300	400	800	mV	2
Data output rise time	tr	-	-	300	ps	3
Data output fall time	tf	-	-	300	ps	3
LOS-High	-	Vcc – 0.5	-	Vcc	V	
LOS-Low	-	Vee	-	Vee+0.5	V	

Notes:

1. AC coupled.
2. Into 100 ohm differential termination.
3. 20 – 80 %

■ **Optical Characteristics (TOP=25°C, Vcc=3.3 Volts)**

Parameter	Symbol	Min	Typ	Max	Unit	Ref.
Transmitter						
Output Opt. Power	PO	-13	-	-6	dBm	1
Optical Wavelength	λ	1470	1490	1510	nm	
Spectral Width(-20dB)	$\Delta \lambda$	-	-	1	nm	
Side Mode Suppression Ratio	SMSR	30			dB	
Optical Rise/Fall Time	tr/tf	-	-	260	ps	2
Total Jitter	TJ	-	-	0.35	UI	
Optical Extinction Ratio	ER	9	-	-	dB	
Receiver						
RX Sensitivity @1.25Gb/s	SENS	-	-	-22	dBm	3, 4
Receiver Overload	-	-2	-	-	dBm	
Optical Center Wavelength	λ_C	1275	-	1350	nm	
LOS De-Assert	LOSD	-	-	-26	dBm	
LOS Assert	LOSA	-40	-	-	dBm	
LOS Hysteresis	-	0.5	-	5	dB	

Notes:

1. Class 1 Laser Safety.
2. Unfiltered, 20-80%. Complies with Gigabit Ethernet eye masks when filtered.
3. Measured with conformance signals defined in FC-PI-2 Rev. 10.0 specifications.
4. Measured with PRBS 2⁷ -1 at 10⁻¹² BER.

■ Mechanical Specifications

Fiberend’s Small Form Factor Pluggable (SFP) transceivers are compatible with the dimensions defined by the SFP Multi-Sourcing Agreement (MSA), dimensions are in mm.

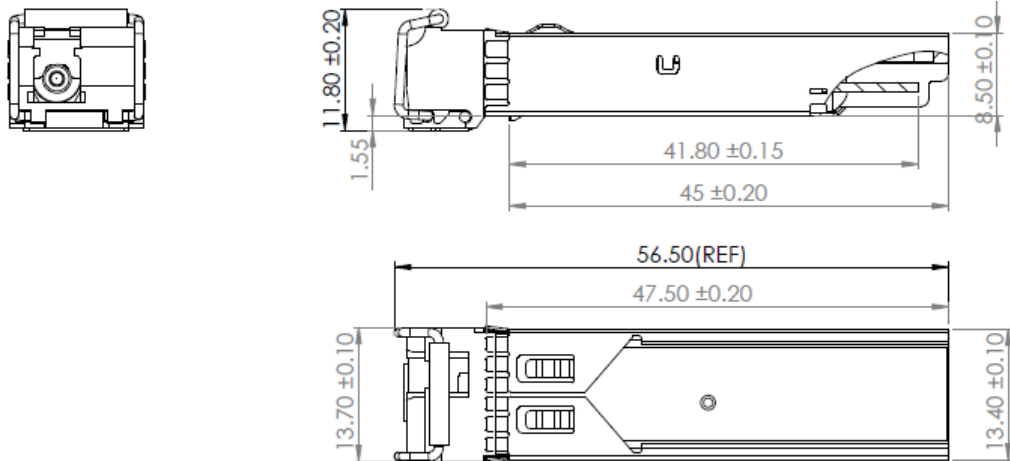

1G-BS4931-SX

■ EEPROM Information

EEPROM memory map specific data field description is as below:

Addr.	Field Size (Bytes)	Name of Field	Hex	Code Value
0	1	Identifier	03	SFP transceiver
1	1	Ext. Identifier	04	MOD_DEF4
2	1	Connector	07	LC
3-10	8	Transceiver	00	
			00	
			00	
			40	BASE-BX10
			20	intermediate distance (I)
			10	Longwave laser (LL)
			01	Single Mode(SM)
		01	100 MBytes/sec	
11	1	Encoding	03	NRZ
12	1	BR, Nominal	1D	1.25 Gb/s (0DH)
13	1	Reserved	00	Unspecified
14	1	Length (9um)-km	03	3(km)
15	1	Length (9um)	1E	(3000m)
16	1	Length (50um)	00	0m

17	1	Length (62.5um)	00	0m
18	1	Length (Copper)	00	0m
19	1	Reserved	00	0m
20-35	16	Vendor name	49 69 62 65 72 65 6e 64 20 20 20 20 20 20 20 20	"Fiberend "(ASC II)
36	1	Transceiver	00	Reserved
37-39	3	Vendor OUI	00	00
			00	00
			00	00
40-55	16	Vendor PN	31 47 2d 42 53 34 39 33 31 2d 53 52 20 20 20 20	"1G-BS4931-SX" (ASCII)
56-59	4	Vendor Rev	41 20 20 20	ASCII("41 20 20 20" means A Revision)
60-61	2	Wavelength	05 D2	Tx Wavelength 1490nm:
62	1	Reserved	00	
63	1	CC_BASE	xx	Check sum of byte 0-62
64-65	2	Options	00 1A	RX_LOS, TX_Fault,
66	1	BR, max	00	0%
67	1	BR, min	00	0%
68-83	16	Vendor SN	20 20 20 20 20 20 20 20 20 20 20 20 20 20 20 20	ASCII
84-91	8	Date code	xx xx xx xx xx xx 20 20	Year(2 bytes),Month(2 bytes), Day(2 bytes)
92	1	Diagnostic Monitoring Type	68	Average power Internally calibrated Digital diagnostic monitoring implemented
93	1	Enhanced Options	F0	Optional soft RX_LOS monitoring implemented; Optional soft TX_FAULT monitoring implemented; Optional soft TX_DISABLE control and monitoring implemented; Optional Alarm/warning flags implemented for all monitored quantities;
94	1	SFF-8472 Compliance	02	Rev 9.5 of SFF-8472
95	1	CC_EXT	xx	Check sum of byte 64-94
96-103	8	Vendor Specific	xx xx xx xx xx xx xx xx	
104-116	13		xx xx xx xx xx xx xx xx xx xx xx xx xx	
			xx xx xx xx xx xx xx xx	
117-126	10		xx xx	
127	10		xx	Check sum of byte 96-126

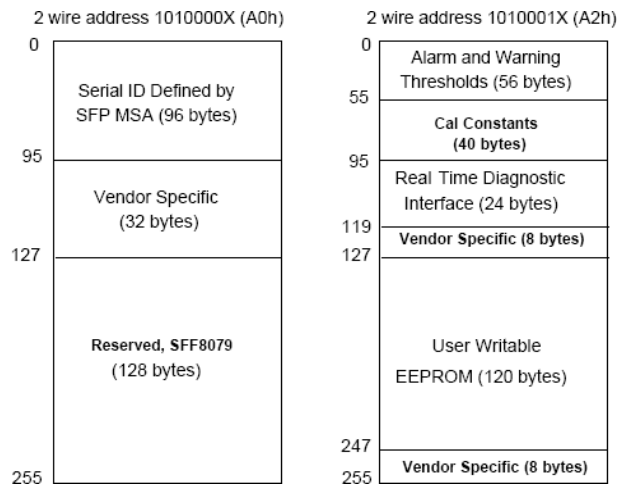

■ Digital Diagnostic Monitoring Interface

Five transceiver parameter values are monitored. The following table defines the monitored parameter's accuracy.

Parameter	Range	Accuracy	Calibration
Temperature	0 to +70°C (C)	±3°C	Internal
	-40 to +85°C (I)		
Voltage	2.97 to 3.63V	±3%	Internal
Bias Current	0 to 100mA	±10%	Internal
TX Power	-13 to -6dBm	±3dB	Internal
RX Power	-22 to -2dBm	±3dB	Internal