

### 10.3 Gb/s SFP+ DWDM Transceiver

#### 10G-DSxx-ER

##### ■ Product Features

- ✓ Supports 9.95 to 11.3Gb/s
- ✓ Duplex LC connector
- ✓ Hot-pluggable SFP footprint
- ✓ Cooled 1550nm EML laser
- ✓ RoHS compliant and Lead Free
- ✓ Up to 40Km link length
- ✓ 100GHz channel spacing
- ✓ Built-in dual CDR
- ✓ Power dissipation  
<2.0W (0~70°C), <2.3W(0~85°C) ,  
<2.3W(-40~85°C)
- ✓ Commercial and industrial operating temperature optional
- ✓ SFP MSA SFF-8472 SFF-8431 SFF-8432 Compliant



##### ■ Applications

- ✓ DWDM 40Km point to point link
- ✓ Fibre Channel 10G
- ✓ 10G Ethernet
- ✓ ITU-T G.698.1 DS100S1-2Dz

##### ■ General

Fiberend's 10G-DSxx-ER Small Form Factor Pluggable (SFP+) transceivers are compatible with SFF-8431, SFF-8432 and support 10G Ethernet ER and 10G Fibre Channel. It is designed for use in 10G-Gigabit multi-rate links up to 40km of G.652. Digital diagnostics functions are available via a 2-wire serial interface, as specified in SFF-8472.

##### ■ Product Selection

Part Number	Operating Case temperature	DDMI
10G-DSxx-ER	Commercial(0~70°C)	Yes
10G-DSxx-ERE	Extend(0~85°C)	Yes
10G-DSxx-ERI	Industrial(-40~85°C)	Yes

### ■ Product Channel Selection

Product Code	ITU channel	Frequency	Center Wavelength(nm)
10G-DS61-ER	61	196.1	1528.77
10G-DS60-ER	60	196.0	1529.55
10G-DS59-ER	59	195.9	1530.33
10G-DS58-ER	58	195.8	1531.12
10G-DS57-ER	57	195.7	1531.90
10G-DS56-ER	56	195.6	1532.68
10G-DS55-ER	55	195.5	1533.47
10G-DS54-ER	54	195.4	1534.25
10G-DS53-ER	53	195.3	1535.04
10G-DS52-ER	52	195.2	1535.82
10G-DS51-ER	51	195.1	1536.61
10G-DS50-ER	50	195.0	1537.40
10G-DS49-ER	49	194.9	1538.19
10G-DS48-ER	48	194.8	1538.98
10G-DS47-ER	47	194.7	1539.77
10G-DS46-ER	46	194.6	1540.56
10G-DS45-ER	45	194.5	1541.35
10G-DS44-ER	44	194.4	1542.14
10G-DS43-ER	43	194.3	1542.94
10G-DS42-ER	42	194.2	1543.73
10G-DS41-ER	41	194.1	1544.53
10G-DS40-ER	40	194.0	1545.32
10G-DS39-ER	39	193.9	1546.12
10G-DS38-ER	38	193.8	1546.92
10G-DS37-ER	37	193.7	1547.72
10G-DS36-ER	36	193.6	1548.51
10G-DS35-ER	35	193.5	1549.32

10G-DS34-ER	34	193.4	1550.12
10G-DS33-ER	33	193.3	1550.92
10G-DS32-ER	32	193.2	1551.72
10G-DS31-ER	31	193.1	1552.52
10G-DS30-ER	30	193.0	1553.33
10G-DS29-ER	29	192.9	1554.13
10G-DS28-ER	28	192.8	1554.94
10G-DS27-ER	27	192.7	1555.75
10G-DS26-ER	26	192.6	1556.55
10G-DS25-ER	25	192.5	1557.36
10G-DS24-ER	24	192.4	1558.17
10G-DS23-ER	23	192.3	1558.98
10G-DS22-ER	22	192.2	1559.79
10G-DS21-ER	21	192.1	1560.61
10G-DS20-ER	20	192.0	1561.42
10G-DS19-ER	19	191.9	1562.23
10G-DS18-ER	18	191.8	1563.05
10G-DS17-ER	17	191.7	1563.86

### ■ Regulatory Compliance

- ESD to the Electrical PINs: compatible with MIL-STD-883 Method 3015
- ESD to the Duplex LC Receptacle: compatible with IEC 61000-4-2
- Immunity compatible with IEC 61000-4-3
- EMI compatible with FCC Part 15 Class B EN55022 Class B (CISPR 22B) VCCI Class B
- Laser Eye Safety compatible with FDA 21CFR 1040.10 and 1040.11 EN60950, EN (IEC) 60825-1,2
- ROHS compliant with ROHS 2 (2011/65/EU)

### ■ Pin Descriptions

Pin	Symbol	Name/Description	Ref.
1	VeeT	Transmitter Ground (Common with Receiver Ground)	1
2	TX Fault	Transmitter Fault. LVTTTL-O	2
3	TX Disable	Transmitter Disable. Laser output disabled on high or open. LVTTTL-I	3
4	SDA	2-Wire Serial Interface Data Line(Same as MOD-DEF2 in INF-8074i). LVTTTL-I/O	2
5	SCL	2-Wire Serial Interface Data Line(Same as MOD-DEF2 in INF-8074i). LVTTTL-I	2
6	Mod_ABS	Module Absent, Connect to VeeT or VeeR in Module.	2
7	RS0	Rate Select 0, optionally controls SFP+ module receiver LVTTTL-I	4
8	LOS	Loss of Signal indication. Logic 0 indicates normal operation. LVTTTL-O	5
9	RS1	Rate Select 1, optionally controls SFP+ module transmitter. LVTTTL-I	4
10	VeeR	Receiver Ground (Common with Transmitter Ground)	1
11	VeeR	Receiver Ground (Common with Transmitter Ground)	1
12	RD-	Receiver Inverted DATA out. AC Coupled. CML-O	
13	RD+	Receiver Non-inverted DATA out. AC Coupled. CML-O	
14	VeeR	Receiver Ground (Common with Transmitter Ground)	1
15	VccR	Receiver Power Supply	6
16	VccT	Transmitter Power Supply	6
17	VeeT	Transmitter Ground (Common with Receiver Ground)	1
18	TD+	Transmitter Non-Inverted DATA in. AC Coupled. CML- I	
19	TD-	Transmitter Inverted DATA in. AC Coupled. CML- I	
20	VeeT	Transmitter Ground (Common with Receiver Ground)	1

**Notes:**

1. Circuit ground is internally isolated from chassis ground.
2. T\_fault is an open collector/drain output. which should be pulled up with a 4.7K – 10K Ohms resistor on the host board if intended for use. Pull up voltage should be between 2.0V to Vcc+0.3V. A high output indicates a transmitter fault caused by either the tx bias current or the tx output power exceeding the preset alarm thresholds. A low output indicates normal operation. In the low state, the output is pulled to <0.8V.
3. Laser output disabled on TX Disable >2.0V or open, enabled on TX Disable <0.8V.
4. Internally pulled down per SFF-8431 Rev4.1 .
5. LOS is open collector output. Should be pulled up with 4.7k – 10kohms on host board to a voltage between 2.0V and 3.6V. Logic 0 indicates normal operation; logic 1 indicates loss of signal.
6. Internally connected

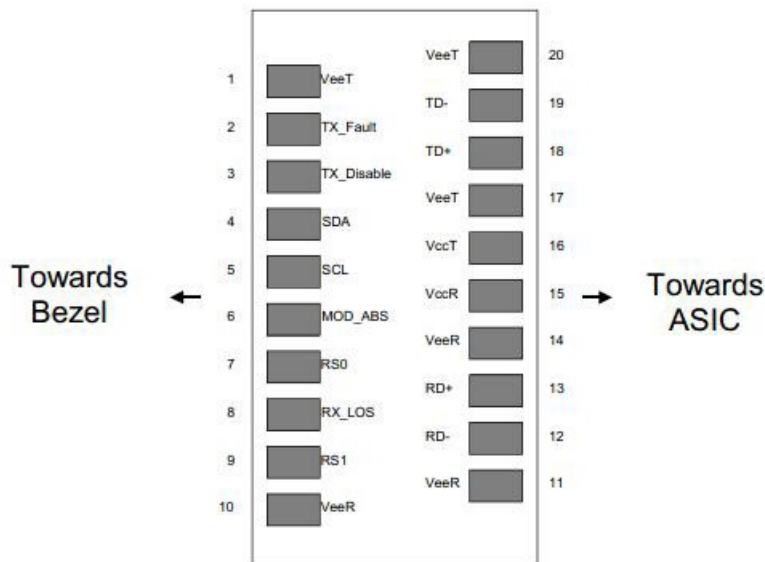

**Pin-out of Connector Block on Host Board**

■ **Recommend Circuit Schematic**

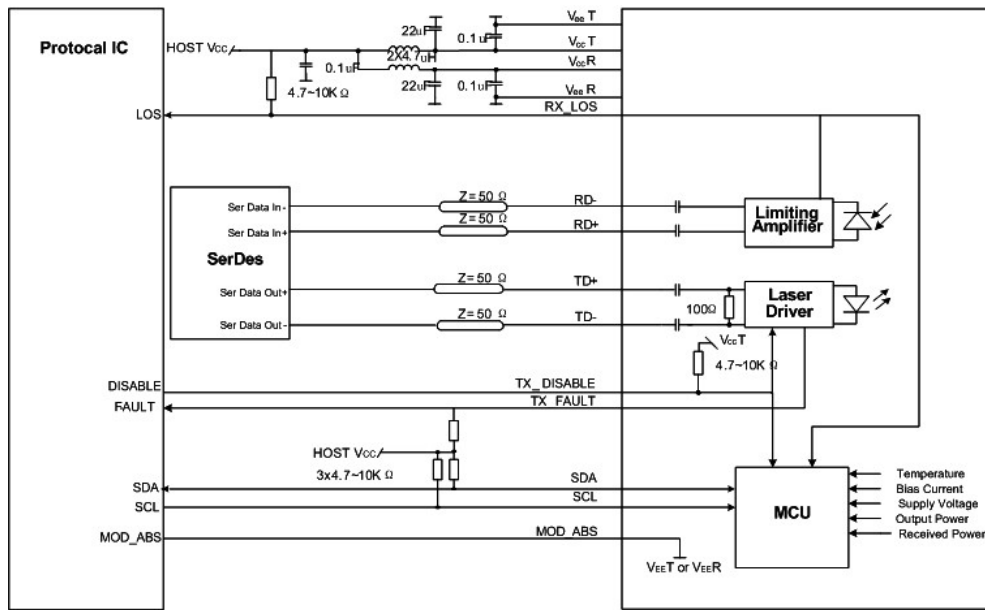

### Absolute Maximum Ratings

Parameter	Symbol	Min	Typ	Max	Unit	Ref.
Maximum Supply Voltage	Vcc	-0.5		+4.0	V	
Storage Temperature	TS	-40		+85	°C	
Operating Humidity	RH	0		85	%	

### Recommended Operating Conditions

Parameter	Symbol	Min	Typ	Max	Unit	Ref.
Power Supply Voltage	Vcc	3.13	3.30	3.47	V	
Power Supply Current	Icc			600	mA	Commercial
	Icc			700	mA	Extend
	Icc			700	mA	Industrial
Case Operating Temperature	Tc	0		+70	°C	Commercial
	Te	0		+85		Extend
	Tl	-4		+85		Industrial
Bit Rate	Br	9.95		11.3	Gbps	
9/125um G.652 SMF	Lmax			40	km	

### ■ Electrical Characteristics (TOP=25°C, Vcc=3.3Volts)

Parameter	Symbol	Min	Typ	Max	Unit	Ref.
<b>Transmitter</b>						
Input differential impedance	Rin	80	100	120	Ω	1
Differential data input swing	Vin, pp	120		850	mV	
TX Disable-High		Vcc – 0.8		Vcc	V	
TX Disable-Low		Vee		Vee+ 0.8	V	
TX Fault-High		Vcc-0.8		Vcc	V	
TX Fault-Low		Vee		Vee+0.8	V	
<b>Receiver</b>						
Single ended data output swing	Vout, pp	300		850	mV	2
Data output rise time	Tr	30			ps	3
Data output fall time	Tf	30			ps	3
LOS-High		Vcc – 0.8		Vcc	V	
LOS-Low		Vee		Vee+0.8	V	

#### **Notes:**

1. AC coupled.
2. Into 100 ohm differential termination.
3. 20 – 80 %

### ■ Optical Characteristics (TOP=25°C, Vcc=3.3 Volts)

Parameter	Symbol	Min	Typ	Max	Unit	Ref.
<b>Transmitter</b>						
Output Opt. Power	PO	-1		4	dBm	
Optical Wavelength	λ	As per ITU-T 694.1			nm	
Side-Mode Suppression Ratio	SMSR	30			dB	
RMS Spectral Width(-20dB)	σ			1	nm	
Optical Extinction Ratio	ER	8.2			dB	
Tx Jitter(SONET)20KHZ-80MHZ	Txj1			0.3	UI	3
Tx Jitter(SONET)4MHZ-80MHZ	TXj2			0.1	UI	3

Path penalty at 800ps/nm@9.95Gb/s				2	dB	
Relative Intensity Noise	RIN			-128	dB/Hz	
Center Wavelength	$\lambda_c$ EOL	z-100	z	Z+100	pm	
<b>Receiver</b>						
RX Sensitivity @10.3 Gb/s	SENS			-16	dBm	1,2
Receiver Overload		-1			dBm	
Optical Center Wavelength	$\lambda_C$	1260		1600	nm	
LOS De-Assert	LOSD			-20	dBm	
LOS Assert	LOSA	-34			dBm	
LOS Hysteresis		0.5			dB	
<b>Rx Noise-Limited Performance(OSNR)</b>						
Bit Rate(Gb/s)	Max CD (ps/nm)	BER-		Max OSNR (dB)		REF
8.5,9.95-10.3	0	1E-12	OSNR1	26	4	
	1450		OSNR2	26	4	
10.7-11.1	0	1E-4	OSNR5	21	4	
	1300		OSNR6	21	4	

### Notes:

1. Measured with conformance signals defined in FC-PI-2 Rev. 10.0 specifications.
2. Measured with PRBS 2<sup>31</sup>-1 at 10<sup>-12</sup> BER.
3. GR-253-CORE Issue 4.
4. With optical input power at the receiver between -1 ~ -11dBm.

### ■ Mechanical Specifications

Fiberend's Small Form Factor Pluggable (SFP+) transceivers are compatible with the dimensions defined by the SFP Multi-Sourcing Agreement (MSA).



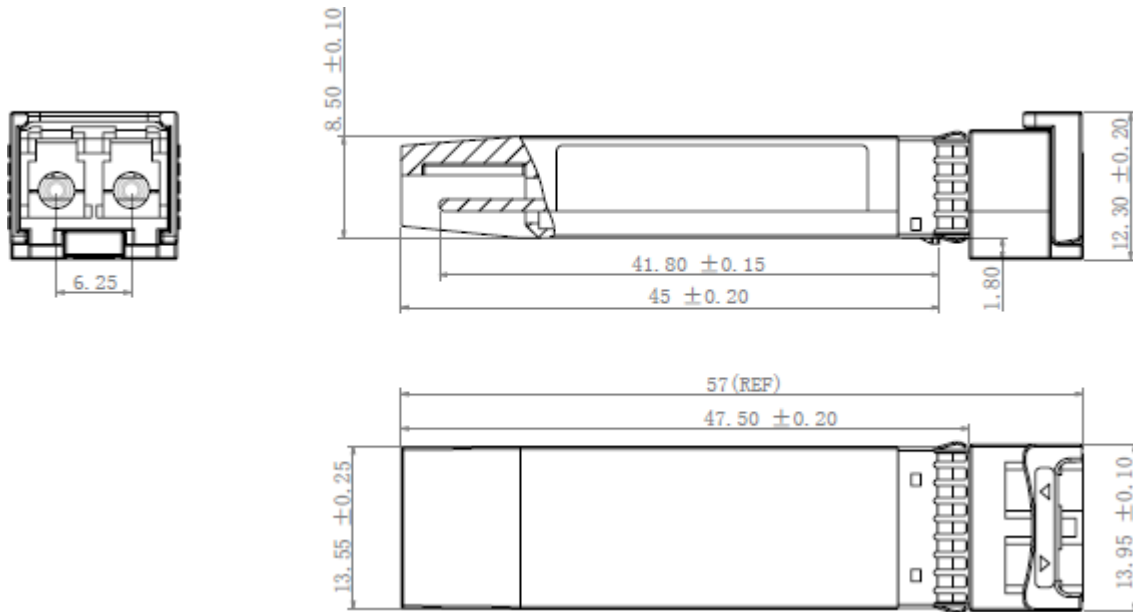

**10G-DSxx-ER**

### ■ EEPROM Information

EEPROM memory map specific data field description is as below:

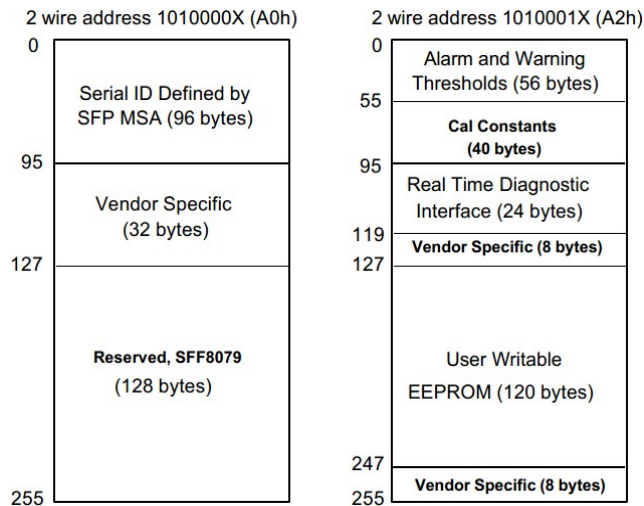

### ■ Digital Diagnostic Monitoring Interface

Five transceiver parameter values are monitored. The following table defines the monitored parameter's accuracy.

Parameter	Range	Accuracy	Calibration
Temperature	0 to +70°C (C)	±3°C	Internal
	0 to +85°C (E)		
	-40 to +85°C (I)		
Voltage	2.97 to 3.63V	±3%	Internal
Bias Current	0 to 100mA	±10%	Internal
TX Power	-1 to 4dBm	±3dB	Internal
RX Power	-16 to -1dBm	±3dB	Internal