

10.3 Gb/s SFP+ CWDM Transceiver

10G-CSxx-ER

■ Product Features

- ✓ Supports 9.95 to 11.3Gb/s
- ✓ Duplex LC connector
- ✓ Hot-pluggable SFP footprint
- ✓ Cooled 1471~1611nm EML laser
- ✓ RoHS compliant and Lead Free
- ✓ Up to 40Km link length
- ✓ Built-in dual CDR
- ✓ Power dissipation
<2.0W (0~70°C), <2.3W(0~85°C) ,
<2.3W(-40~85°C)
- ✓ Commercial and industrial operating temperature optional
- ✓ SFP MSA SFF-8472 SFF-8431 SFF-8432 Compliant



■ Applications

- ✓ CWDM Networks
- ✓ 10GBASE-ER/EW

■ General

Fiberend's 10G-CSxx-ER Small Form Factor Pluggable (SFP+) transceivers are compatible with SFF-8431, SFF-8432 and support 10G Ethernet ER and 10G Fibre Channel. It is designed for use in 10G-Gigabit multi-rate links up to 40km of G.652. Digital diagnostics functions are available via a 2-wire serial interface, as specified in SFF-8472.

■ Product Selection

Part Number	Operating Case temperature	DDMI
10G-CSxx-ER	Commercial(0~70°C)	Yes
10G-CSxx-ERE	Extend(0~85°C)	Yes
10G-CSxx-ERI	Industrial(-40~85°C)	Yes

■ Product Channel Selection

Part Number	Wavelength	Data Rate	Distance
10G-CS47-ER	1471nm EML	9.95G~11.3G	40KM
10G-CS49-ER	1491nm EML	9.95G~11.3G	40KM
10G-CS51-ER	1511nm EML	9.95G~11.3G	40KM
10G-CS53-ER	1531nm EML	9.95G~11.3G	40KM
10G-CS55-ER	1551nm EML	9.95G~11.3G	40KM
10G-CS57-ER	1571nm EML	9.95G~11.3G	40KM
10G-CS59-ER	1591nm EML	9.95G~11.3G	40KM
10G-CS61-ER	1611nm EML	9.95G~11.3G	40KM

■ Regulatory Compliance

- ESD to the Electrical PINs: compatible with MIL-STD-883 Method 3015
- ESD to the Duplex LC Receptacle: compatible with IEC 61000-4-2
- Immunity compatible with IEC 61000-4-3
- EMI compatible with FCC Part 15 Class B EN55022 Class B (CISPR 22B) VCCI Class B
- Laser Eye Safety compatible with FDA 21CFR 1040.10 and 1040.11 EN60950, EN (IEC) 60825-1,2
- ROHS compliant with ROHS 2 (2011/65/EU)

■ Pin Descriptions

Pin	Symbol	Name/Description	Ref.
1	VeeT	Transmitter Ground (Common with Receiver Ground)	1
2	TX Fault	Transmitter Fault. LVTTTL-O	2
3	TX Disable	Transmitter Disable. Laser output disabled on high or open. LVTTTL-I	3
4	SDA	2-Wire Serial Interface Data Line(Same as MOD-DEF2 in INF-8074i). LVTTTL-I/O	2
5	SCL	2-Wire Serial Interface Data Line(Same as MOD-DEF2 in INF-8074i). LVTTTL-I	2

6	Mod_ABS	Module Absent, Connect to VeeT or VeeR in Module.	2
7	RS0	Rate Select 0, optionally controls SFP+ module receiver LVTTL-I	4
8	LOS	Loss of Signal indication. Logic 0 indicates normal operation. LVTTL-O	5
9	RS1	Rate Select 1, optionally controls SFP+ module transmitter. LVTTL-I	4
10	VeeR	Receiver Ground (Common with Transmitter Ground)	1
11	VeeR	Receiver Ground (Common with Transmitter Ground)	1
12	RD-	Receiver Inverted DATA out. AC Coupled. CML-O	
13	RD+	Receiver Non-inverted DATA out. AC Coupled. CML-O	
14	VeeR	Receiver Ground (Common with Transmitter Ground)	1
15	VccR	Receiver Power Supply	6
16	VccT	Transmitter Power Supply	6
17	VeeT	Transmitter Ground (Common with Receiver Ground)	1
18	TD+	Transmitter Non-Inverted DATA in. AC Coupled. CML- I	
19	TD-	Transmitter Inverted DATA in. AC Coupled. CML- I	
20	VeeT	Transmitter Ground (Common with Receiver Ground)	1

Notes:

1. Circuit ground is internally isolated from chassis ground.
2. T_fault is an open collector/drain output. which should be pulled up with a 4.7K – 10K Ohms resistor on the host board if intended for use. Pull up voltage should be between 2.0V to Vcc+0.3V. A high output indicates a transmitter fault caused by either the tx bias current or the tx output power exceeding the preset alarm thresholds. A low output indicates normal operation. In the low state, the output is pulled to <0.8V.
3. Laser output disabled on TX Disable >2.0V or open, enabled on TX Disable <0.8V.
4. Internally pulled down per SFF-8431 Rev4.1 .
5. LOS is open collector output. Should be pulled up with 4.7k – 10kohms on host board to a voltage between 2.0V and 3.6V. Logic 0 indicates normal operation; logic 1 indicates loss of signal.
6. Internally connected

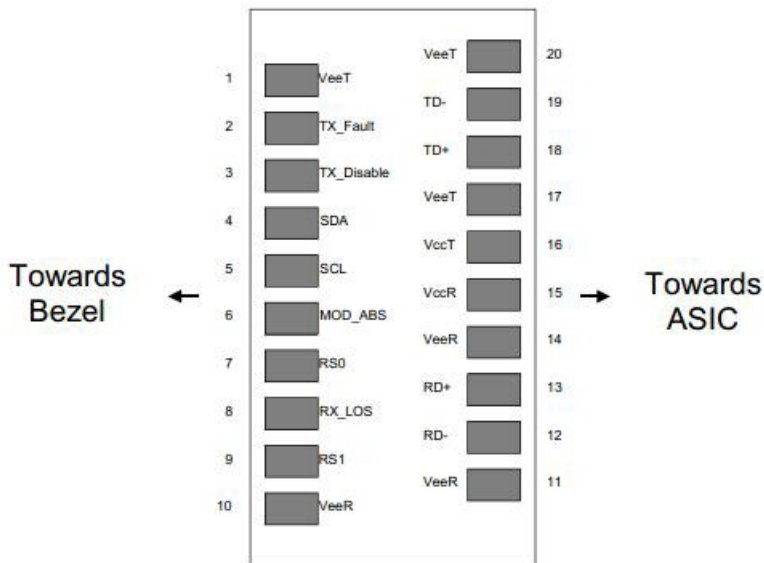

Pin-out of Connector Block on Host Board

Recommend Circuit Schematic

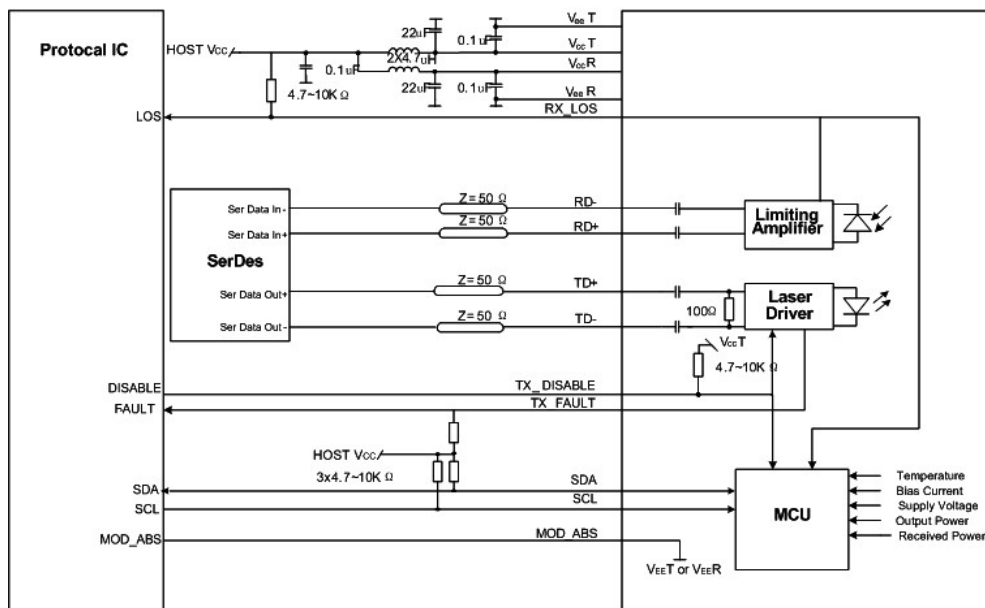

Absolute Maximum Ratings

Parameter	Symbol	Min	Typ	Max	Unit	Ref.
Maximum Supply Voltage	Vcc	-0.5		+4.0	V	
Storage Temperature	TS	-40		+85	°C	
Operating Humidity	RH	0		85	%	

■ Recommended Operating Conditions

Parameter	Symbol	Min	Typ	Max	Unit	Ref.
Power Supply Voltage	Vcc	3.13	3.30	3.47	V	
Power Supply Current	Icc			600	mA	Commercial
	Icc			700	mA	Extend
	Icc			700	mA	Industrial
Case Operating Temperature	Tc	0		+70	°C	Commercial
	Te	0		+85		Extend
	Tl	-40		+85		Industrial
Bit Rate	Br	9.95		11.3	Gbps	
9/125um G.652 SMF	Lmax			40	km	

■ Electrical Characteristics (TOP=25°C, Vcc=3.3Volts)

Parameter	Symbol	Min	Typ	Max	Unit	Ref.
Transmitter						
Input differential impedance	Rin	80	100	120	Ω	1
Differential data input swing	Vin, pp	120		850	mV	
TX Disable-High		Vcc – 0.8		Vcc	V	
TX Disable-Low		Vee		Vee+ 0.8	V	
TX Fault-High		Vcc-0.8		Vcc	V	
TX Fault-Low		Vee		Vee+0.8	V	
Receiver						
Single ended data output swing	Vout, pp	300		850	mV	2
Data output rise time	Tr	30			ps	3
Data output fall time	Tf	30			ps	3
LOS-High		Vcc – 0.8		Vcc	V	
LOS-Low		Vee		Vee+0.8	V	

Notes:

1. AC coupled.
2. Into 100 ohm differential termination.
3. 20 – 80 %

■ Optical Characteristics (TOP=25°C, Vcc=3.3 Volts)

Parameter	Symbol	Min	Typ	Max	Unit	Ref.
Transmitter						
Output Opt. Power	PO	-1		4	dBm	
Optical Wavelength	λ	$\lambda - 6.5$		$\lambda + 6.5$	nm	
Side-Mode Suppression Ratio	SMSR	30			dB	
RMS Spectral Width(-20dB)	σ			1	nm	
Relative Intensity Noise	RIN			-128	dB/Hz	
Path penalty at 800ps/nm@9.95Gb/s				2	dB	
Optical Extinction Ratio	ER	8.2			dB	
Receiver						
RX Sensitivity @10.3 Gb/s	SENS			-16	dBm	1,2
Receiver Overload		-1			dBm	
Optical Center Wavelength	λ_C	1260		1620	nm	
LOS De-Assert	LOSD			-20	dBm	
LOS Assert	LOSA	-34			dBm	
LOS Hysteresis	-	0.5			dB	

Notes:

1. Measured with conformance signals defined in FC-PI-2 Rev. 10.0 specifications.
2. Measured with PRBS $2^{31}-1$ at 10^{-12} BER.

■ Mechanical Specifications

Fiberend's Small Form Factor Pluggable (SFP+) transceivers are compatible with the dimensions defined by the SFP Multi-Sourcing Agreement (MSA).

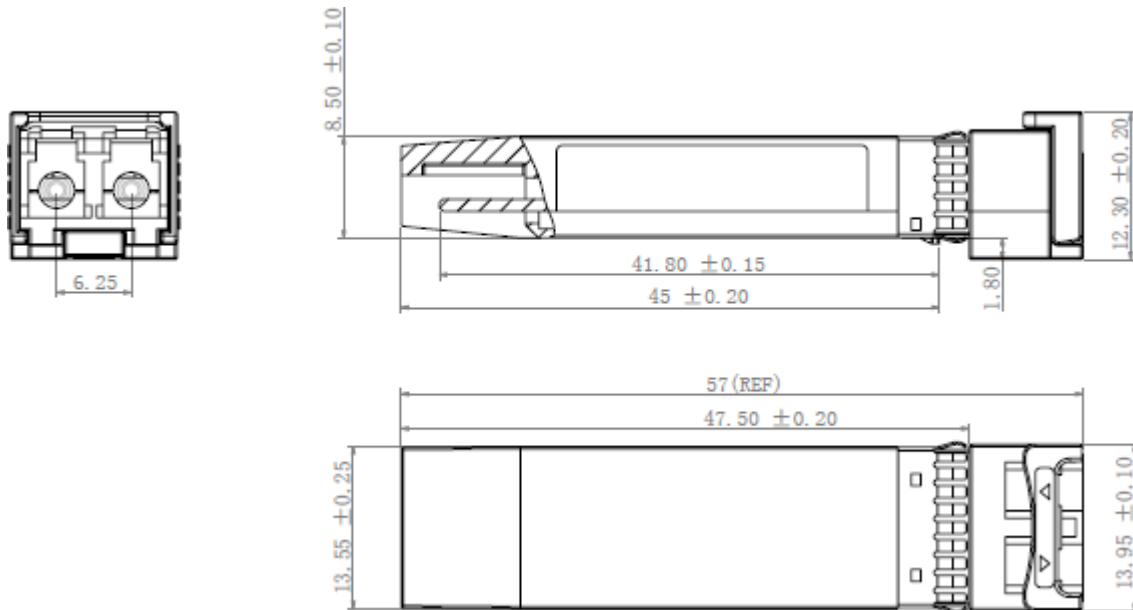

10G-CSxx-ER

■ EEPROM Information

EEPROM memory map specific data field description is as below:

2 wire address 1010000X (A0h)		2 wire address 1010001X (A2h)	
0	Serial ID Defined by SFP MSA (96 bytes)	0	Alarm and Warning Thresholds (56 bytes)
95		55	Cal Constants (40 bytes)
127	Vendor Specific (32 bytes)	95	Real Time Diagnostic Interface (24 bytes)
255	Reserved, SFF8079 (128 bytes)	119	Vendor Specific (8 bytes)
		127	User Writable EEPROM (120 bytes)
		247	Vendor Specific (8 bytes)
		255	255

■ Digital Diagnostic Monitoring Interface

Five transceiver parameter values are monitored. The following table defines the monitored parameter's accuracy.

Parameter	Range	Accuracy	Calibration
Temperature	0 to +70°C (C)	±3°C	Internal
	0 to +85°C (E)		
	-40 to +85°C (I)		
Voltage	2.97 to 3.63V	±3%	Internal
Bias Current	0 to 100mA	±10%	Internal
TX Power	-1 to 4dBm	±3dB	Internal
RX Power	-16 to -1dBm	±3dB	Internal